

Standardtype

Ventil in Ruhestellung geschlossen - (NC). Bei erregtem Magnet baut sich die Druckdifferenz von der Sekundärseite des Kolben über die Servobohrung ab. Die wirksame Druckdifferenz hebt den Kolben vom Ventilsitz ab. Der angegebene Mindestdruck muss als Druckdifferenz für eine einwandfreie Funktion der Servosteuerung immer vorhanden sein.

Standard type

Valve normally closed - (NC). When energised, the pressure decomposes from the secondary side of the piston via the pilot hole. The pressure differential lifts the piston from the seat (orifice). The stated minimum pressure is always necessary as pressure differential for accurate operation.



Steuerungsart: Type of control:	Servogesteuert Pilot operated	Metall. Innenteile: Metallic internals:	Edelstahl 1.4104 Stainless steel 1.4104 (AISI 430F)
Konstruktion: Construction:	Kolbenventil Piston design	Dichtung: Seal:	Tecapeek Tecapeek
Anschluß: Connection:	G1/8-G2 DIN ISO 228 G1/8-G2 DIN ISO 228	Einbaulage: Installation:	beliebig, Magnet vorzugsweise stehend actuator, in any position, upw. is recomm.
Druck: Pressure:	1-450 bar (s. Tabelle) 1-450 bar (see table)	Anschlußspannung: Supply voltage:	AC: 24,42,110,230V 50Hz bzw. 60Hz DC: 24,110,205V=
Durchflußmedium: Medium:	neutrale, gasförmige u. flüssige Medien neutral, gaseous and liquid medium	Spannungstoleranz: Voltage tolerance:	+5% / -10% +5% / -10%
Viskosität: Viscosity:	22mm ² /S 22mm ² /S (centistokes)	Leistungsaufnahme: Power-consumption:	.702/3702 = 25 Watt .322/3332 = 30 Watt .242/5242 = 46 Watt .328/5328 = 23 Watt .248/5248 = 30 Watt .218/5218 = 7 Watt .272/5272 = 100 Watt .278/5278 = 47 Watt
Mediumtemperatur: Medium temperature:	-60°C bis +90°C -60°C up to +90°C	Schutzart: Protection class:	IP65 nach DIN 40050 IP65 acc. to DIN 40050
Umgebungstemperatur: Ambient temperature:	+35°C +35°C	Einschaltdauer: Duty factor:	100% ED-VDE 0580 100% ED-VDE 0580
Ventilgehäuse: Body material:	../06../.. = Edelst. 1.4305/St. steel (AISI 303) ../08../.. = Edelst. 1.4571/St. steel (AISI 316Ti) ../09../.. = Edelst. 1.4104/St. Steel (AISI 430F)	Kabelanschluß: Cable connection:	Gerätestecker DIN 43650 / Klemmkasten DIN 43650 - plug / terminal box

G	Sitz Orifice mm	Kv-Wert Flow-rate m ³ /h	Standardtype Standard type	max. Druck bei Magnettype max. pressure regarding solenoid type							
				.702	.322	ExII2GEEExemIICT4 .328	ExII2GEEExdIICT4 .218	.242	ExII2GEEExemIIIT4 .248	.272	ExII2GEEExemIIIT4 .278
1/8	6	0,75	2/529-37-..15-....	1-150	1-350	1-300	1-250	-	1-350	-	-
1/4	6	0,75	2/529-47-..15-....	1-150	1-350	1-300	1-250	-	1-350	-	-
3/8	6	0,75	2/529-57-..15-....	1-150	1-350	1-300	1-250	-	1-350	-	-
1/2	6	0,75	2/529-67-..15-....	1-150	1-350	1-300	1-250	-	1-350	-	-
1/4	12	1,8	2/529-21-..15-....	1-140	1-250	1-250	1-250	1-350	1-350	-	-
3/8	12	3,3	2/529-22-..15-....	1-140	1-250	1-250	1-250	1-350	1-350	-	-
1/2	12	3,8	2/529-23-..15-....	1-140	1-250	1-250	1-250	1-350	1-350	-	-
3/4	25	11,5	2/529-24-..15-....	-	1-220	1-220	-	1-300	1-300	-	-
1	25	13,0	2/529-25-..15-....	-	1-220	1-220	-	1-350	1-300	-	-
5/4	40	22,0	2/529-26-..15-....	-	-	-	-	1-200*	1-100	1-200	1-150
6/4	40	24,0	2/529-27-..15-....	-	-	-	-	1-200*	1-100	1-200	1-150
2	50	32,0	2/529-28-..15-....	-	-	-	-	1-200*	1-100	1-200	1-150

* = mit PTFE/with PTFE max. 150 bar

Stückliste - Parts list

Baureihe 2/529 / Type 2/529

- K101 Armatur / Valve body
- K201 Deckel / Bonnet
- K202 Vorsteuersitz / Pilot seat
- *K203 O-Ring / O-ring
- K301 Verschraubung / Screw joint
- *K303 O-Ring / O-ring
- *K304 O-Ring / O-ring
- *K305 Dichtung / Sealing
- *K306 Scheibe / Disk
- *K307 Kolben / Piston
- *K308 Kolbenführungsband / Piston guide band
- *K309 Senkschraube / Screw
- *K310 Vorsteuerspindel / Pilot spindle
- *K311 Feder / Spring
- *K312 Dichtung / Sealing
- *K313 Spindelkopf / Spindle head
- *K315 Mutter / Nut
- *K316 Feder / Spring
- *K317 O-Ring / O-ring
- *K319 Feder / Spring
- *K322 Stift / Pin
- K501 Magnethülse / Solenoid tube
- K502 Magnetanker / Plunger
- K503 Gegenkern / Tube head
- K504 Druckstück / Pressure piece
- K505 O-Ring / O-ring
- K506 O-Ring / O-ring
- K507 Scheibe / Disk
- K508 Zylinderschraube / Screw
- K509 Federring / Spring ring
- K601 Magnet / Solenoid

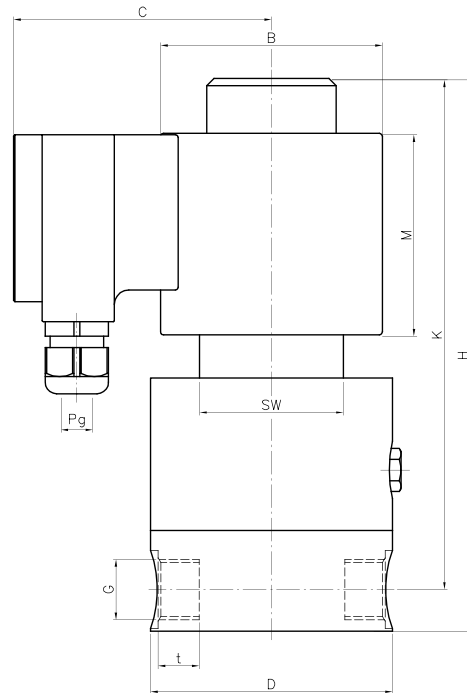
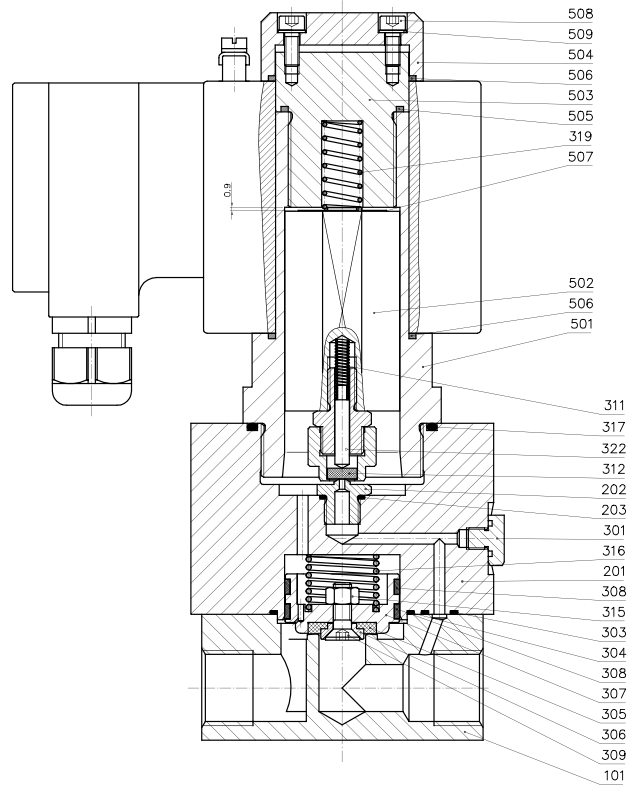

* = Bestandteil des Ersatzteilpäckchens
(je nach Ausführung freibleibend)
* = Part of the service set (These specifications are without obligation).

Magnet Solenoid	.242	.322/ .328			.242/ .248				.272/ .278	
Type	..21-24	..23-23	..24-25	..21-23	..24-25	..26-27	..28	..23-25	..26-27	..28
G	1/4-1/2	1/4-1/2	3/4-1	1/4-1/2	3/4-1	5/4-2	5/4-2	5/4-6/4	5/4-2	5/4-2
B	35x35	Ø77	Ø105	Ø77	Ø77	Ø77	Ø77	Ø77	Ø77	Ø77
C	67	82	105,5	82	90	90	90	90	90	90
H	155	200	195	200	262	262	273	262	262	273
K	140	185	170	185	235	229	236	235	229	236
D	84	84	96	84	110	155	170	110	155	170
M	50	70	90	70	70	70	70	70	70	70
SW	30	50	65	50	55	55	55	55	55	55
t	12	12	15	12	15	22	22	22	22	22
Pg	11	13,5	13,5	13,5	13,5	13,5	13,5	13,5	13,5	13,5



GSR Ventiltechnik GmbH & Co. KG
 Postfach 2060 • D-32595 Vlotho • Im Meisenfeld 1 • D-32602 Vlotho
 Telefon (05228) 779-0 • Telefax (05228) 779-90
 E-mail: info@ventiltechnik.de http://www.ventiltechnik.de